

ITEM NO.	PART NUMBER	DESCRIPTION	FINISH	WEIGHT (PER)	QTY.
1	MP1013.01	24" RING MOUNT STAND-OFF (WELDMENT)	H.D.G.	51.06	1
2	GU43550	1/2" x 5-1/2" x 3-5/8" x 2-1/2" U-BOLT	H.D.G.	0.77	4
3	GF04	1/2" FLAT WASHER	H.D.G.	0.04	8
4	GL04	1/2" LOCK WASHER	H.D.G.	0.02	8
5	GN04A	1/2" HEX NUT (2H)	H.D.G.	0.06	8
6	GB0522A	5/8" x 2-1/4" HEX BOLT	H.D.G.	0.31	4
7	GL05	5/8" LOCK WASHER	H.D.G.	0.03	4
8	GN05A	5/8" HEX NUT (2H)	H.D.G.	0.12	4

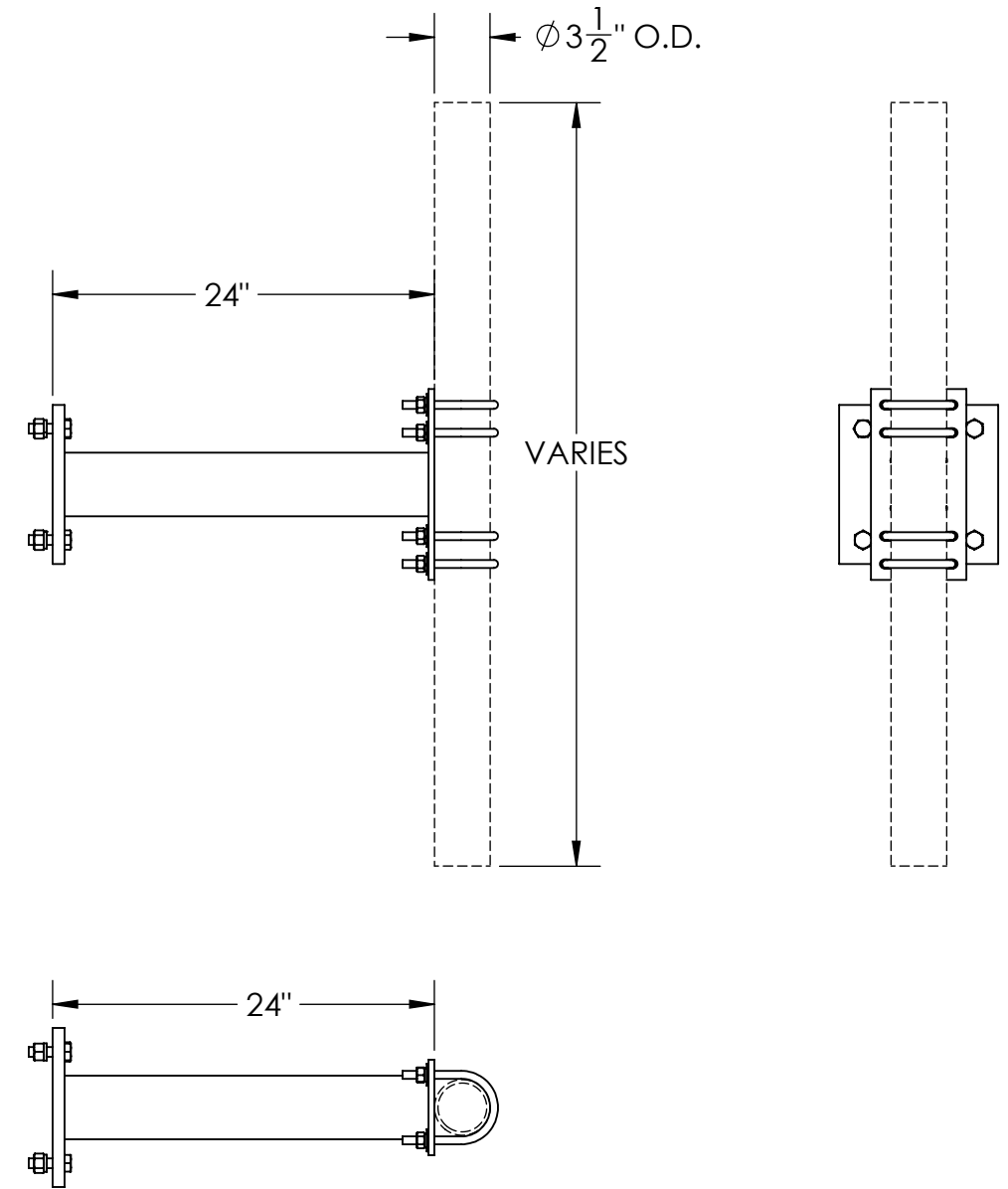
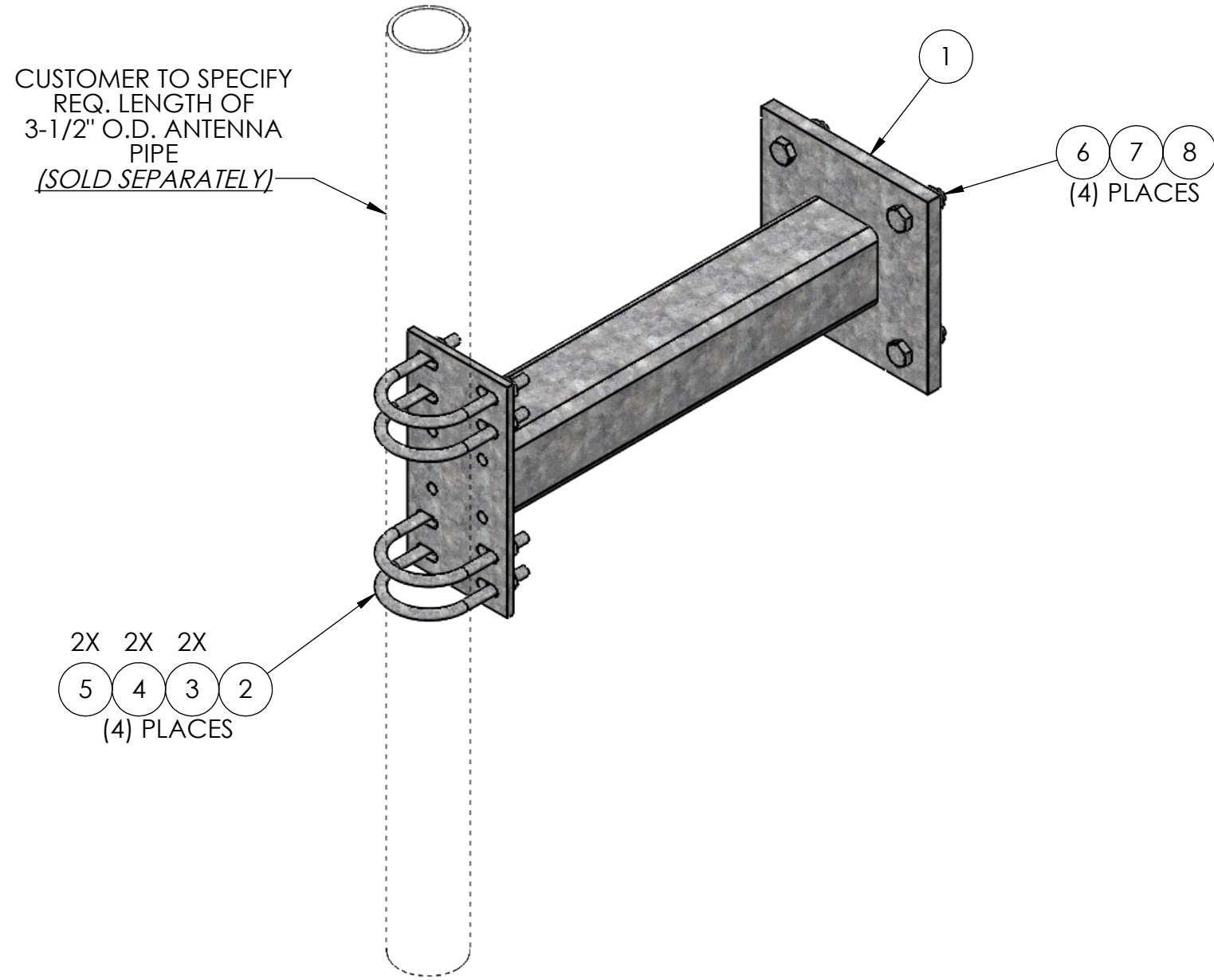

UNLESS OTHERWISE SPECIFIED: DIMENSIONS ARE IN INCHES TOLERANCE $\pm 1/16$		DESCRIPTION: 24" RING MOUNT STAND-OFF FOR 3-1/2" O.D. ANTENNA PIPE	
MATERIAL: -		 <b>PRO TOWER MANUFACTURING L.L.C.</b> 5601 San Francisco St. NE Albuquerque, N.M. 87109 (505) 924-2810	DWG NO: MP1015
FINISH: H.D.G.			DRAWN BY: AJK CHECKED BY: E.FILMER SHEET: 1 of 1
SIZE: <b>B</b>		PROPRIETARY AND CONFIDENTIAL THE INFORMATION CONTAINED IN THIS DRAWING IS THE SOLE PROPERTY OF PRO TOWER MANUFACTURING L.L.C. ANY REPRODUCTION IN PART OR AS A WHOLE WITHOUT THE WRITTEN PERMISSION OF PRO TOWER MANUFACTURING L.L.C. IS PROHIBITED.	
		REV: _____ WEIGHT: 56.92	