

DETAIL B
SCALE 1 : 6

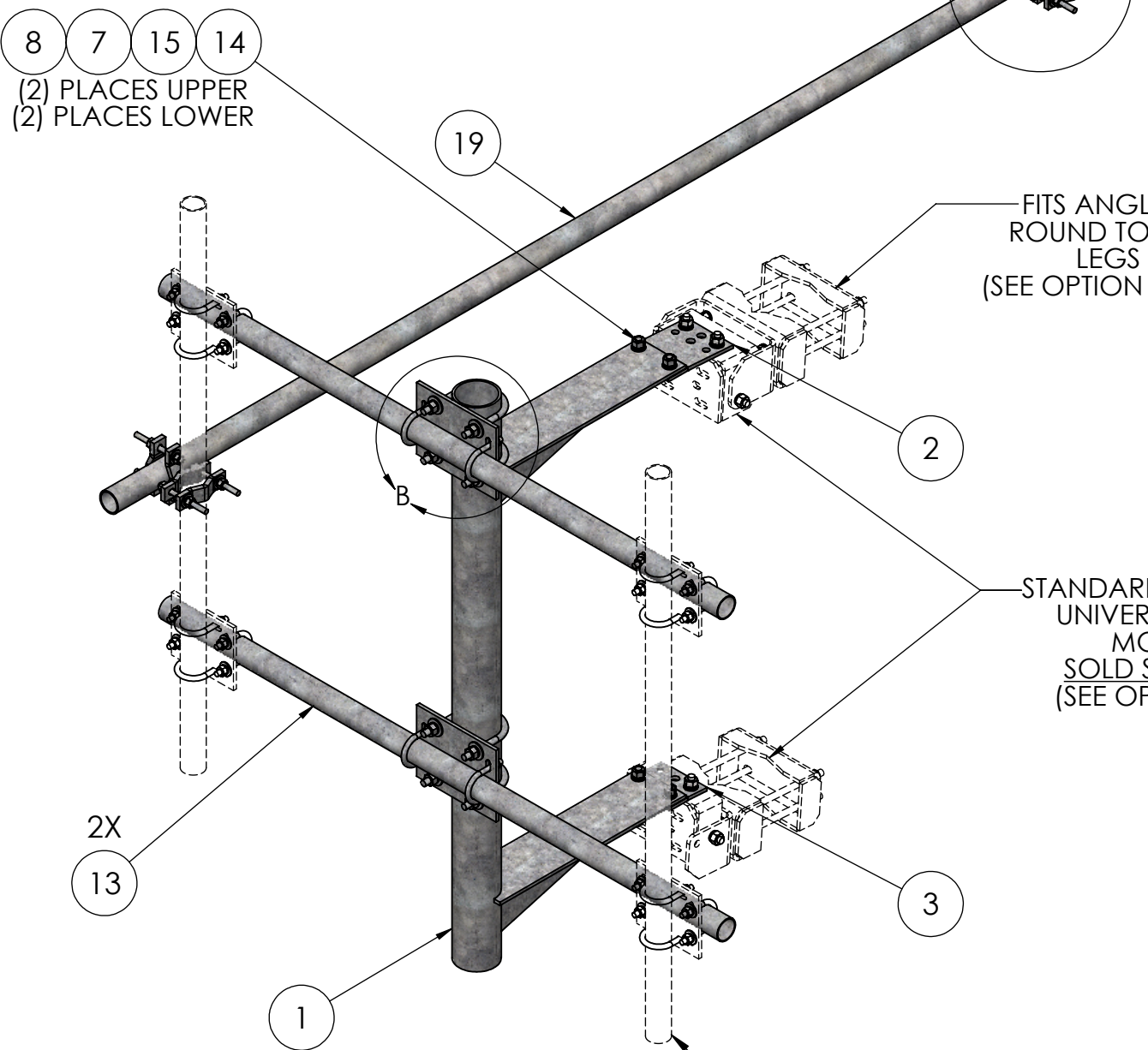

FITS ANGLE &
ROUND TOWER
LEGS
(SEE OPTION TABLE)

STANDARD & LONG LEG
UNIVERSAL SADDLE
MOUNT KIT
SOLD SEPARATELY
(SEE OPTION TABLE)

ANTENNA PIPE MOUNT KITS
SOLD SEPARATELY

ITEM NO.	PART NUMBER	DESCRIPTION	FINISH	WEIGHT (PER)	QTY.
1	TW1260.01	STRAIGHT TOWER 2' STAND-OFF PIPE MOUNT (WELDMENT)	H.D.G.	98.86	1
2	TW1010.02	UPPER ADAPTER PLATE (3/8" PLATE)	H.D.G.	5.00	1
3	TW1010.03	LOWER ADAPTER PLATE (3/8" PLATE)	H.D.G.	2.98	1
4	TW1107	LARGE CROSSOVER PLATE (3/8" PLATE)	H.D.G.	8.22	2
5	GU54564	5/8" x 6-1/2" x 4-5/8" x 3" U-BOLT	H.D.G.	1.45	4
6	GF05	5/8" FLAT WASHER	H.D.G.	0.08	8
7	GL05	5/8" LOCK WASHER	H.D.G.	0.03	12
8	GN05A	5/8" HEX NUT (2H)	H.D.G.	0.12	12
9	GU42440	1/2" x 4" x 2-1/2" x 2" U-BOLT	H.D.G.	0.57	4
10	GF04	1/2" FLAT WASHER	H.D.G.	0.04	24
11	GL04	1/2" LOCK WASHER	H.D.G.	0.02	24
12	GN04A	1/2" HEX NUT (2H)	H.D.G.	0.06	24
13	GP2375.078	2-3/8" x O.D. 78" PLAIN END GALV PIPE	H.D.G.	14.63	2
14	GB0516A	5/8" x 1-3/4" HEX BOLT	H.D.G.	0.26	4
15	GF05A	5/8" FLAT WASHER	H.D.G.	0.03	4
16	TW1320.01	CLAMP HALF 1-1/2" TO 3-1/2" OD ROUND (1/2" PLATE)	H.D.G.	1.20	4
17	TW1315.01	CROSS OVER CLAMP BRACKET, SM TO SM (WELDMENT)	H.D.G.	2.40	2
18	GR500.006	1/2" x 6" THREADED ROD	H.D.G.	0.33	8
19	GP2375.126	2-3/8" O.D. x 126" PLAIN END GALV PIPE	H.D.G.	38.49	1

UNIVERSAL SADDLE MOUNT KIT (SOLD SEPARATELY)			
PART NUMBER	DESCRIPTION	FITS (ANGLE & PIPE TOWER LEGS)	QTY.
TW1126	UNIVERSAL SADDLE MOUNT	L2-3/4" TO L4-1/2" / Ø1-3/4" TO Ø6-5/8" O.D.	1
TW1128	UNIVERSAL SADDLE MOUNT (LONG LEG ADAPTER KIT)	L3" TO L8-1/2" / Ø1-3/4" TO Ø12" O.D.	1

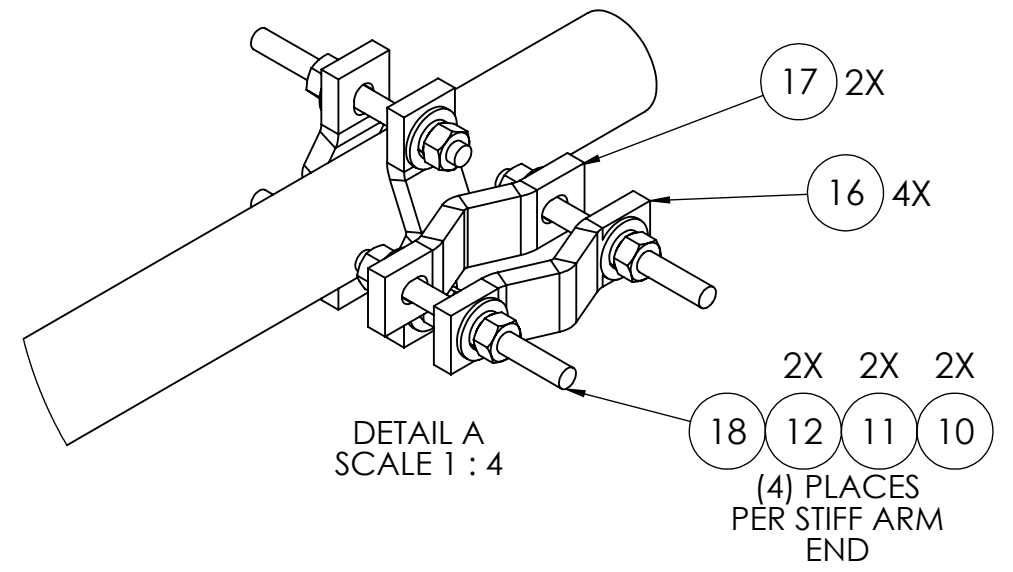

DETAIL A
SCALE 1 : 4

UNLESS OTHERWISE SPECIFIED: DIMENSIONS ARE IN INCHES TOLERANCE ± 1/16		DESCRIPTION: 6'-6" HD T-SECTOR FRAME, 2' STAND-OFF, ANTENNA PIPE NOT INCLUDED	
PROPRIETARY AND CONFIDENTIAL THE INFORMATION CONTAINED IN THIS DRAWING IS THE SOLE PROPERTY OF PRO TOWER MANUFACTURING L.L.C. ANY REPRODUCTION IN PART OR AS A WHOLE WITHOUT THE WRITTEN PERMISSION OF PRO TOWER MANUFACTURING L.L.C. IS PROHIBITED.		 PRO TOWER MANUFACTURING L.L.C. 5601 San Francisco St. NE Albuquerque, N.M. 87109 (505) 924-2810	
OLD PART NUMBER: N/A	FINISH H.D.G.	DWG NO: TW1002.078	DRAWN BY: AJK CHECKED BY: E. FILMER SHEET: 1 of 1
SIZE B		DATE: 8/9/2022	REV
		DATE: 8/9/2022	WEIGHT: 217.83
		SCALE: NTS	