

FITS:  
-2-3/8" TO 5-9/16" O.D.  
ROUND  
MEMBERS

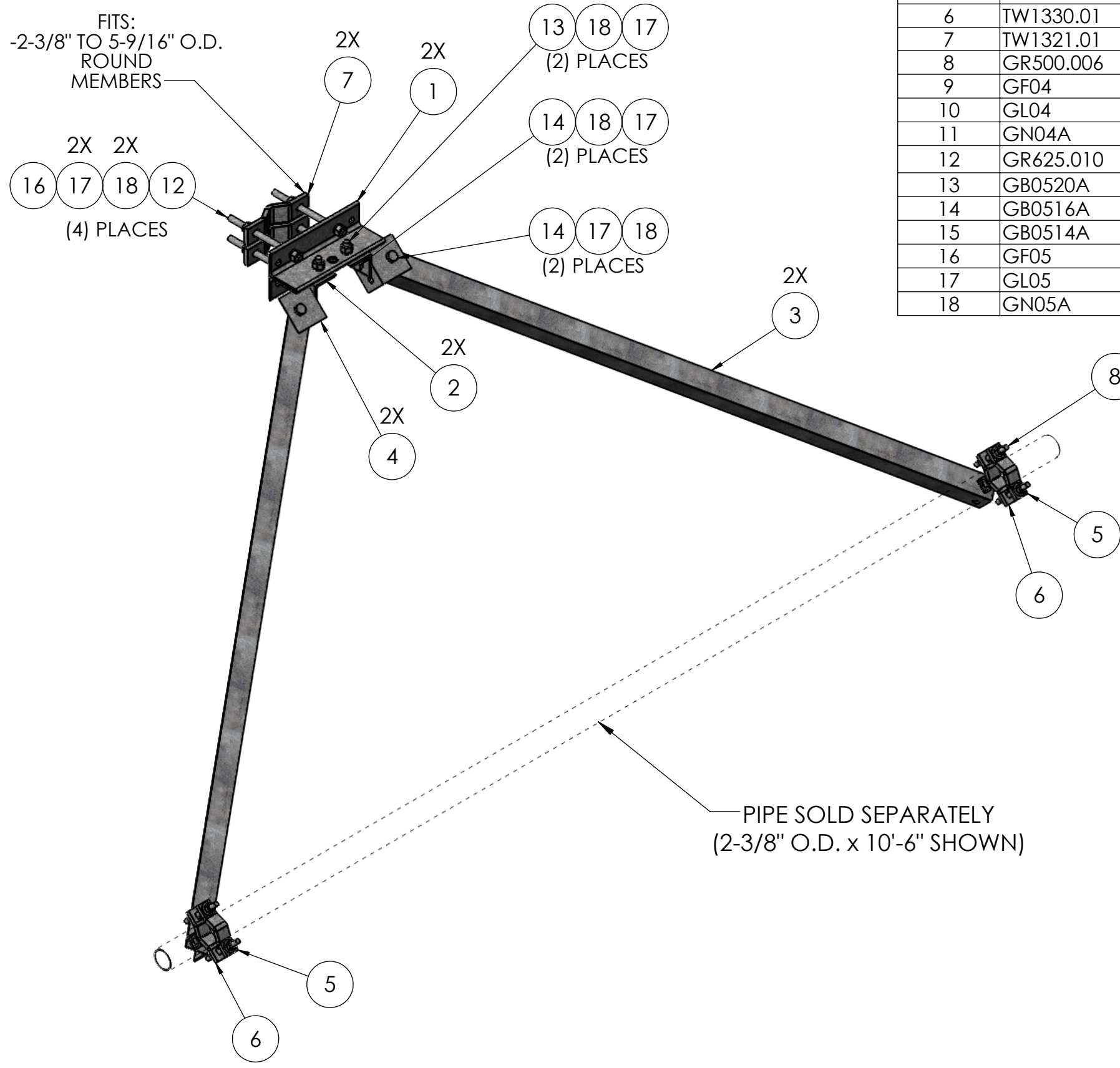

ITEM NO.	PART NUMBER	DESCRIPTION	FINISH	WEIGHT(PER)	QTY.
1	TW1120.01	SADDLE MOUNT ANGLE BRACKET (L4" x 3" x 1/4" x 12-1/2")	H.D.G.	5.79	2
2	TW1334.01	SWIVEL ANGLE BRACKET (L3" x 3" x 1/4" x 3")	H.D.G.	1.17	2
3	TW1086.01	UNIVERSAL ANGLE BRACE x 72" (L2-1/2" x 2-1/2" x 3/16")	H.D.G.	18.24	2
4	TW1086.02	SWIVEL ANGLE BRACKET (L4" x 3" x 1/4" x 4")	H.D.G.	1.83	2
5	TW1320.01	CLAMP HALF 1-1/2" TO 3-1/2" OD ROUND (1/2" PLATE)	H.D.G.	1.20	2
6	TW1330.01	STIFF ARM MOUNT CLAMP (WELDMENT)	H.D.G.	1.58	2
7	TW1321.01	CLAMP HALF 2-3/8" TO 5-9/16" O.D. ROUND (1/2" PLATE)	H.D.G.	2.44	2
8	GR500.006	1/2" x 6" THREADED ROD	H.D.G.	0.33	4
9	GF04	1/2" FLAT WASHER	H.D.G.	0.04	8
10	GL04	1/2" LOCK WASHER	H.D.G.	0.02	8
11	GN04A	1/2" HEX NUT (2H)	H.D.G.	0.06	8
12	GR625.010	5/8" X 10" THREADED ROD	H.D.G.	0.72	4
13	GB0520A	5/8" x 2" HEX BOLT	H.D.G.	0.28	2
14	GB0516A	5/8" x 1-3/4" HEX BOLT	H.D.G.	0.26	4
15	GB0514A	5/8" x 1-1/2" HEX BOLT	H.D.G.	0.24	2
16	GF05	5/8" FLAT WASHER	H.D.G.	0.08	4
17	GL05	5/8" LOCK WASHER	H.D.G.	0.03	16
18	GN05A	5/8" HEX NUT (2H)	H.D.G.	0.12	16

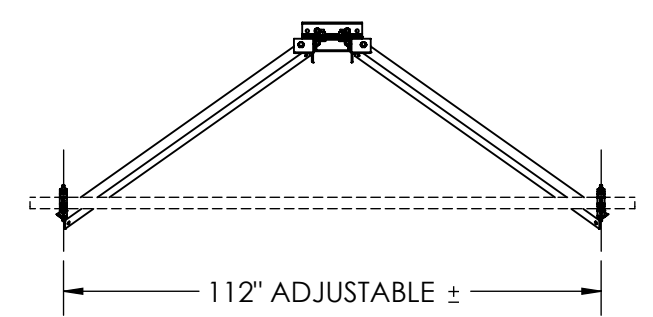
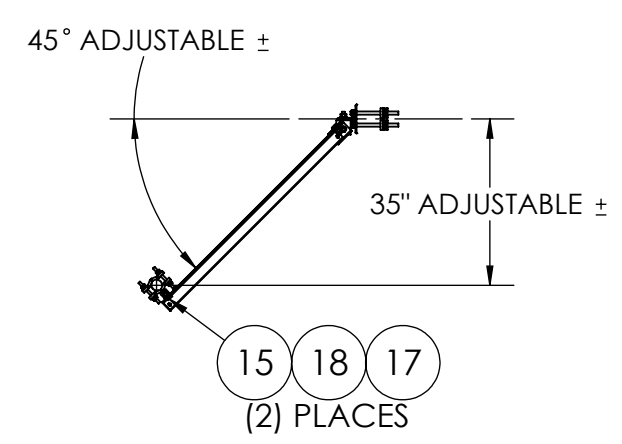
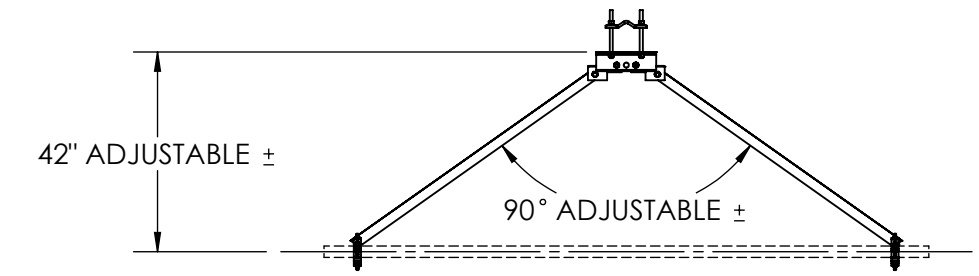

PIPE SOLD SEPARATELY  
(2-3/8" O.D. x 10'-6" SHOWN)

UNLESS OTHERWISE SPECIFIED: DIMENSIONS ARE IN INCHES TOLERANCE ± 1/16		DESCRIPTION: SECTOR FRAME STABILIZER, VERTICAL 42" ADJ. STAND-OFF, FITS 2-3/8 - 5-9/16" O.D. PIPE	
MATERIAL	FINISH	 <b>PRO TOWER MANUFACTURING L.L.C.</b> 5601 San Francisco St. NE Albuquerque, N.M. 87109 (505) 924-2810	DWG NO: TW1086-M
-	H.D.G.		DRAWN BY: AJK CHECKED BY: E. FILMER SHEET: 1 of 1
SIZE <b>B</b>	PROPRIETARY AND CONFIDENTIAL THE INFORMATION CONTAINED IN THIS DRAWING IS THE SOLE PROPERTY OF PRO TOWER MANUFACTURING L.L.C. ANY REPRODUCTION IN PART OR AS A WHOLE WITHOUT THE WRITTEN PERMISSION OF PRO TOWER MANUFACTURING L.L.C. IS PROHIBITED.		REV WEIGHT: 75.03